



## TVW21 Skoda Fabia 2021>, Seat Ibiza 2017>, Volkswagen Polo 2017>

Item	Qty	Description	Item	Qty	Description
A	1	TVW21 Crossbar	F	2	M16 x 50 Bolts & Nyloc Nuts
B1	1	Left Hand Side Arm	G	2	M12 x 100 (10.9) Bolts & Nyloc Nuts
B2	1	Right Hand Side Arm	H	4	M6 x 20 Self Tapping Bolts
			J	4	M12 x 35 Bolts & S/P Washers
D	1	Extension	K	4	M12 x 40 Bolts & Nyloc Nuts
			L	4	6 X 15 Flat Washers
T1	2	30 O/D 40mm Long Tube	M	12	12 x 25 Flat Washers
X		OEM GSM Ariel	N	4	12 x 30 Flat Washers

### Bumper Removal:

1. Open tailgate and remove light clusters, one fixing behind boot trim panel each side.
2. Remove the three fixings from the wheel arch liner and mudguards if fitted and the tip screw from each side.
3. Remove the seven fixings from the lower bumper edge.
4. Pull bumper out sideways and release clips from under the light clusters pull rearwards, unplug the reversing sensors and number plate lights and fully remove.
5. Remove item **X**, one fixing from off the rear crash beam if fitted, then remove the crash beam, seven fixings.  
Note: (This will not be refitted with the towbar assembly). Refit the fixings into the rear panel to prevent water ingress.
6. Separate the charcoal cannister from the offside chassis to gain access to the mounting point, two fixings.

### Towbar Installation:

1. Loosely fix items **B1** and **B2** to the correct chassis rail using items **J** with items **N** on the correct setting for the vehicle. (Figure 1)
2. Loosely fix item **A** to items **B1** and **B2** using items **K** with items **M**.
3. Fully tighten all the fixings ensuring the Towbar is rigid, square and secure.
4. If applicable remount item **X** to item **A** using items **H** and items **L**.
5. Remount the charcoal canister and rear bumper. Note: (Some models may require pre-marked cut to be removed from bumper).
6. Loosely fix item **D** to item **A** with items **T1** on the correct setting (Figure 2) using items **G** and items **M**.
7. Using items **F** secure your desired ball bracket and wiring plate (Not supplied in this kit) to item **D**.
8. Fully tighten all remaining fixings.

Figure 1



Purple:- Skoda Fabia 2021>

Green:- Seat Ibiza 2017> / Volkswagen Polo 2017>

Figure 2



Red:- Not Used

Cyan:- All Models

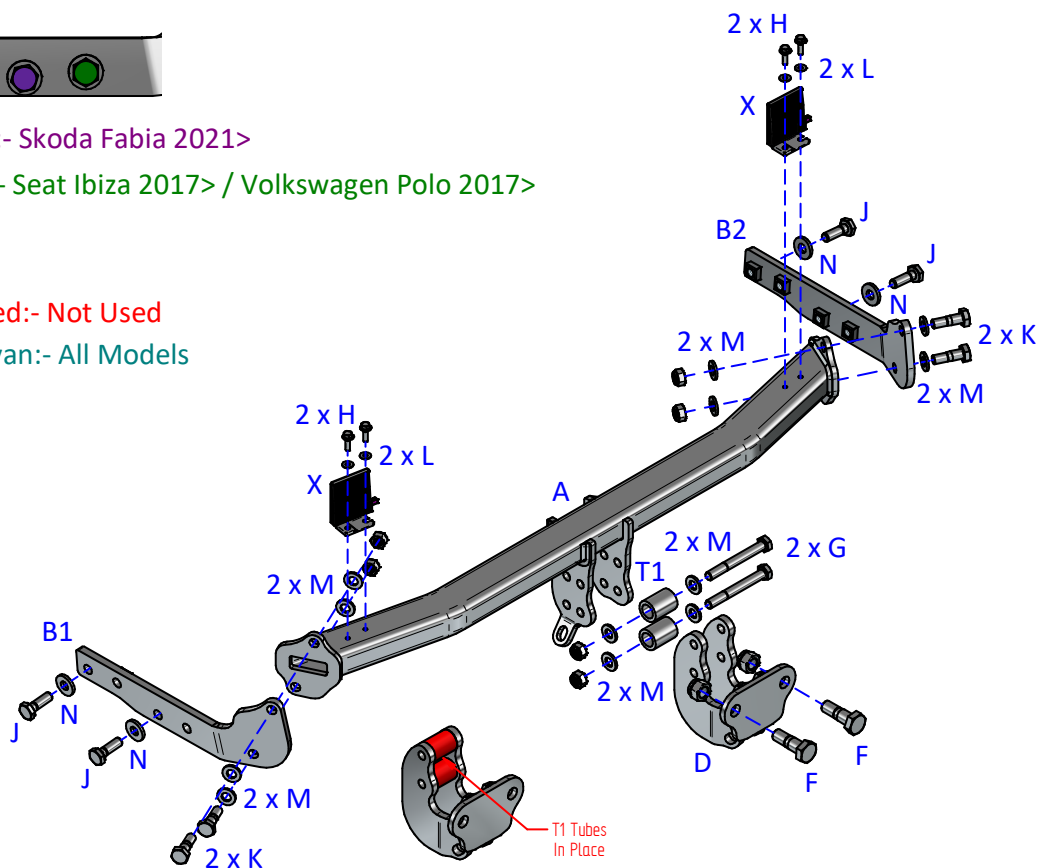

### Notes:

1. For Torque settings see general notes overleaf.
2. Nose load limits and vehicle manufacturer's trailer / caravan weight limits must be observed.
3. We recommend the use of PRO-TOW Couplings with all our products.