



Fitting Instructions

TOWBAR F157U
Ford Focus 4 Saloon
2011 -

MATERIALS

A	1	Cross Bar
B	2	Side Arm
C	4	M12 x 40 x 1.75mm Bolts, and Serrated Flange Nuts
D	4	M10 x 40 x 1.5mm Bolts, Lock Washers, Flat Washers (30mm O.D.), Witter Cage Nuts & Retainers.
ZE	1	Electrical Plate Kit
ZB	1	Electrical Plate Angle Bracket
ZX	1	3002 Series Neck Kit

FITTING

1. Remove bumper (3 screws on each wheel arch liner, 1 tip screw, 2 screws on top edge, 2 plastic screws on lower edge, pull each tip from retaining clips to remove.)
2. Remove bumper beam.
3. Pre-assemble the Witter Cage Nuts to Side Arms (B) using separate fitting instructions, and taking care to fit to opposite sides of each Side Arm as shown below.
4. Insert Side Arms (B) into chassis rails and loosely attach to existing holes in outside face using fasteners (D).
5. Loosely attach Cross Bar (A) to Side Arms (B) using fasteners (C).
6. Assemble the chosen Neck Kit (ZX), Electrical Plate Bracket (ZB) and Electrical Plate (ZE to Cross Bar (A) using the kit instructions and fasteners.
7. **Fully tighten all bolts.**
8. Re-fit bumper.
9. Either Cut and replace the plastic under tray, or leave off and hand to customer.

Note: This towbar must be used with either a Witter Towball (part number Z11 or Z16) or Class A50-1 or A50-X towball dimensionally conforming to A50-1 with a 'D' and 'S' value greater than or equal to that of the towbar.

Please refer to the vehicle specification for the trailer weight and nose limits, which **must be observed**.

Recommended torque settings: M8 - 27Nm, M10 - 53 Nm, M12 - 95 Nm, M14 - 150 Nm, M16 - 214 Nm

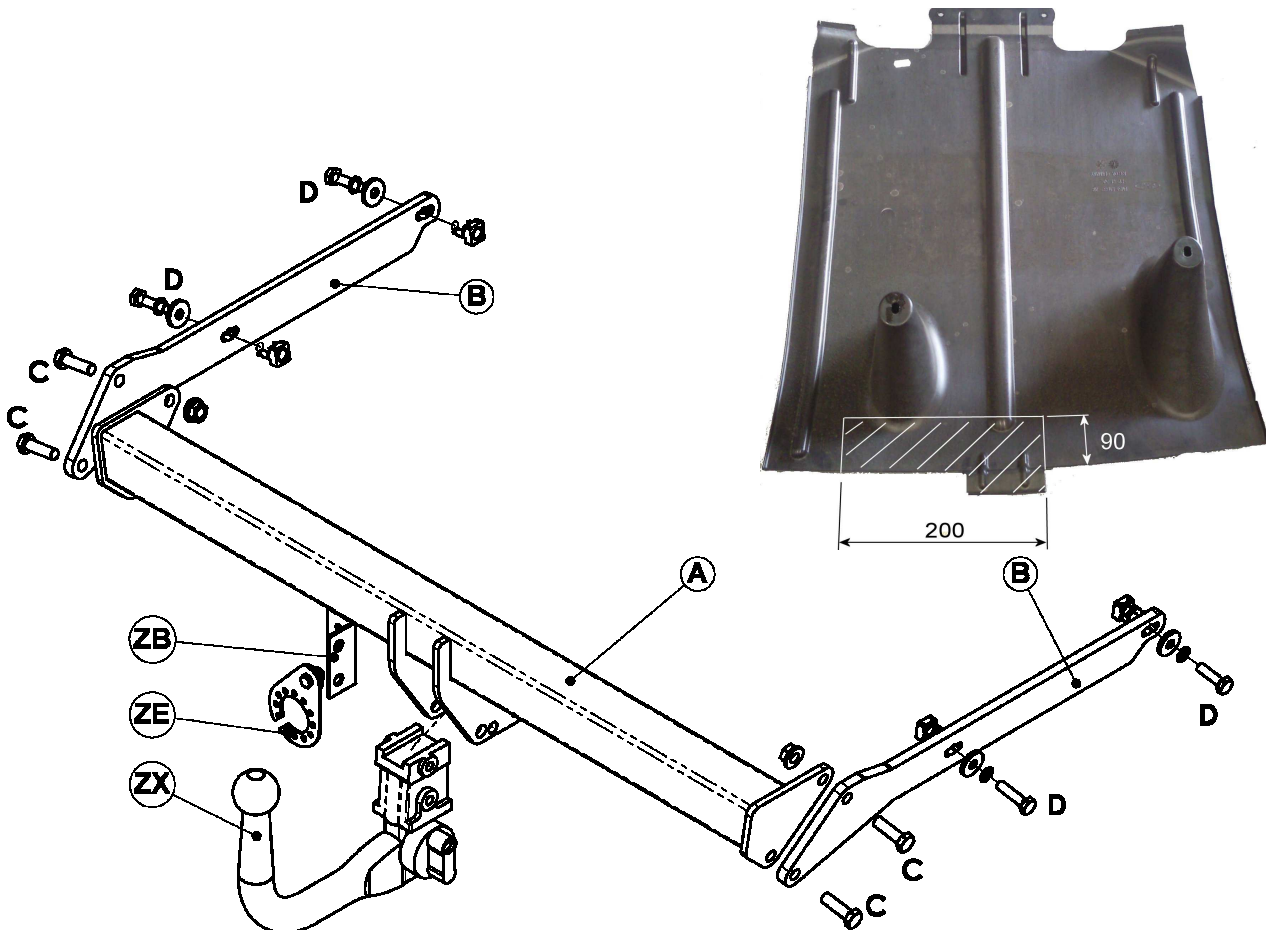

W0001F157U-FIT\$011108290000